

## CASTER LEG REAR SLANTED 3.0 INSTALLATION INSTRUCTIONS

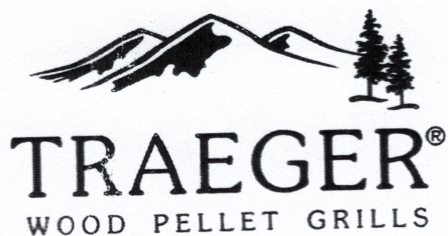

**CAUTION!** Do not attempt to replace parts unless you are qualified to do so. If you require help in replacing parts please feel to contact Traeger Customer service at: 1-800-872-3437 between the hours of 5AM PST to 7PM PST 7 days a week.

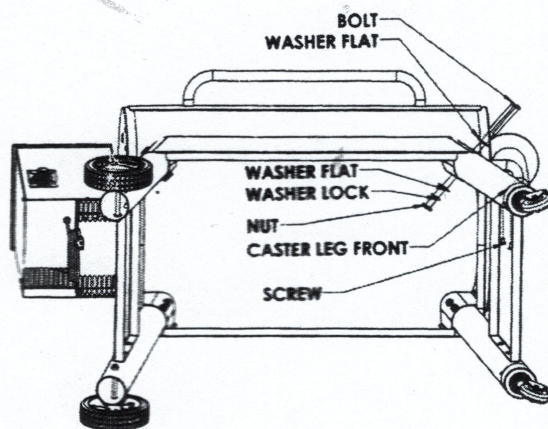

**Tools required:** Phillips screw driver, 3/16" hex key wrench and 1/2" open end wrench.

To replace the legs may require you to lay the grill on its back or lift one end far enough to get the legs out. If you lay the grill down it is best to remove all the pellets from the hopper and take out all the porcelain grill, drip pan, and heat shield. Place a piece of cardboard down for the grill to rest on. This may require 2 persons.

### Installation Instructions:

1. Insert the castor leg right front into the leg socket and align holes in the leg with holes in the grill frame.
2. Insert a flat washer onto the bolt and insert into the slot located on the side. Then from the inside of the grill insert flat washer, lock washer. Thread on the nut to the bolt but do not tighten. Repeat with other bolt.
3. Insert screw onto the inside of the brace and thread into the leg but do not tighten. Repeat this with the other screw.
4. With the grill in the upright position ensure that the legs are all making contact to the ground. Then tighten the bolts and screws on the leg replaced.